

THE TRUTH ABOUT AIR CARS

VOLUME 2

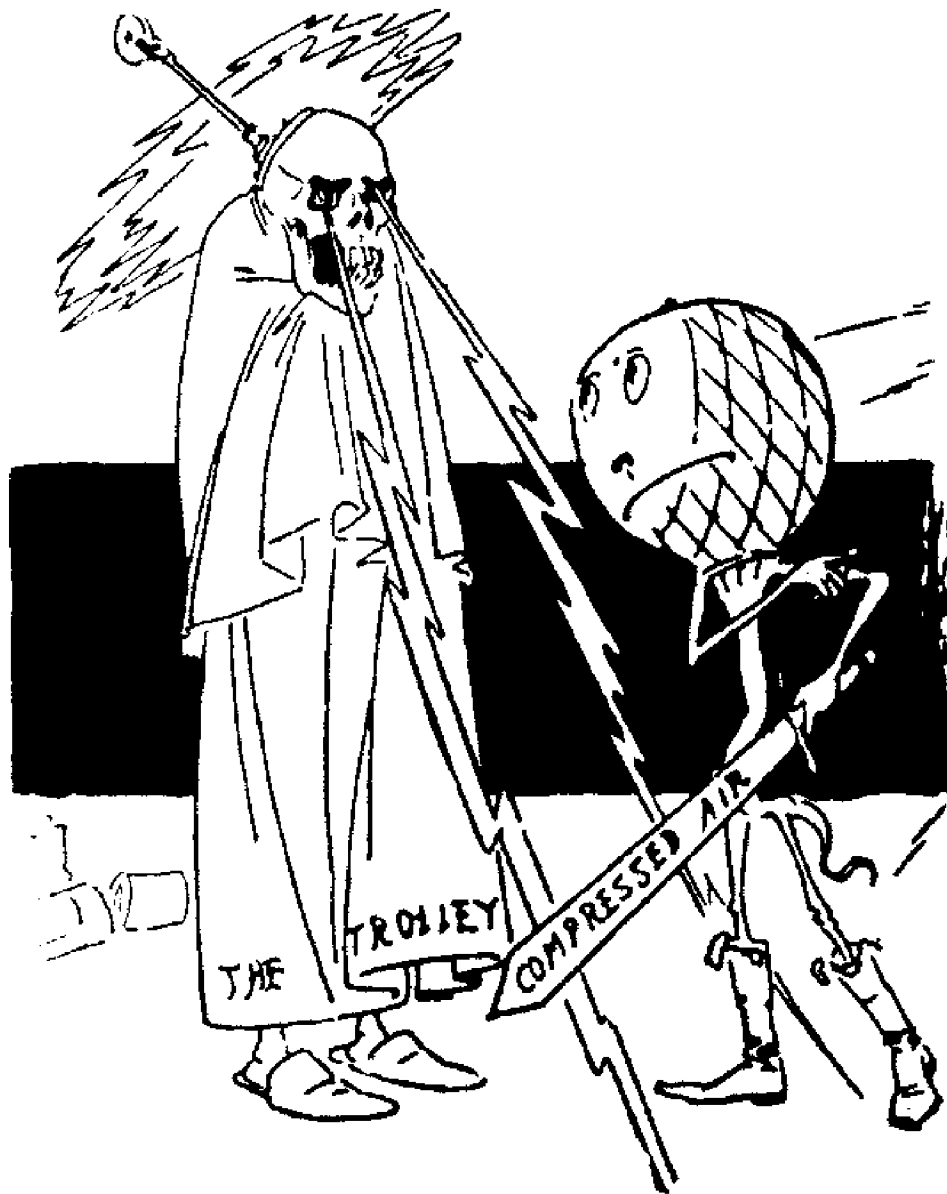

THE TROLLEY HAS A RIVAL.
From Chicago-Times Herald.

THE TRUTH ABOUT AIR CARS

VOLUME 2

CONTENTS

1. Compressed air locomotives (mostly used for mining, and mostly compound and triple expansion engines), 1905-1930	1
2. Hybrid diesel-compressed air 1200 horsepower locomotive, 1930	126
3. Costs of pneumatic locomotives in mining, 1933	134
4. The Perrymobile (air/steam hybrid), 1945	137
5. Compressed Air Magazine archives from 1896, air trolleys	140
6. Air locomotives in mining, 1952-1954	142
7. Air powered dragster, 1962	147
8. Vittorio Sorgato's air car, 1975	149
9. Terry Miller's Air Car One, 1980	152
10. Oskar Coester and Aeromovel, air powered mass transit today	158

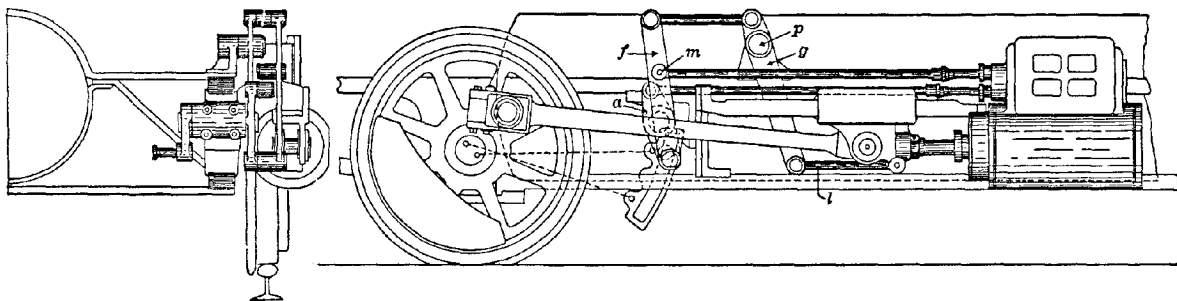
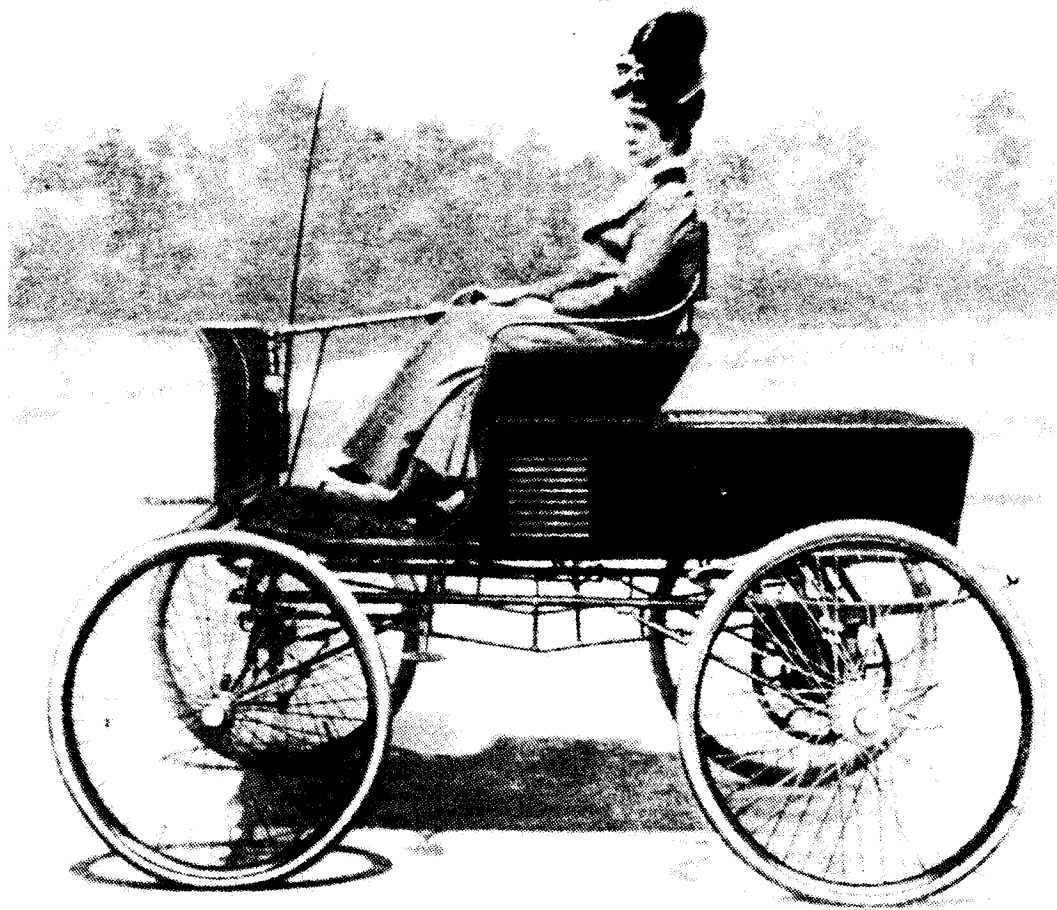

FIG. 412.—SIDE AND END ELEVATION OF THE MOTOR.

ABOVE: The Hardie Air Engine, used for street transit in New York City and Copenhagen



It has been said that there is nothing new under the sun. Files of potential articles in the editorial office today contain one marked "Pneumatic Car." It will discuss current activities in the area. The January 1900 issue showed this automobile operated by compressed air and built by The American Vehicle Company, NY.

ABOVE: Compressed Air Magazine, March 1906, page 15