

Pulsejet engine.

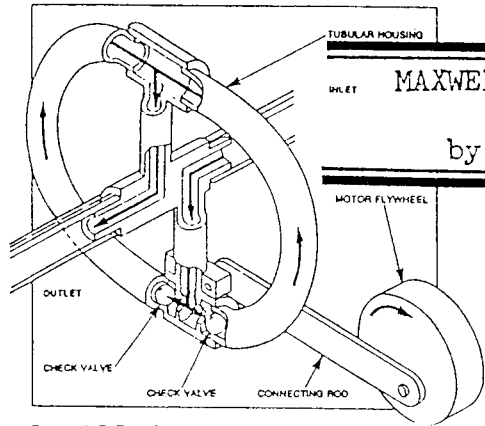

Oscillating Loop Pump

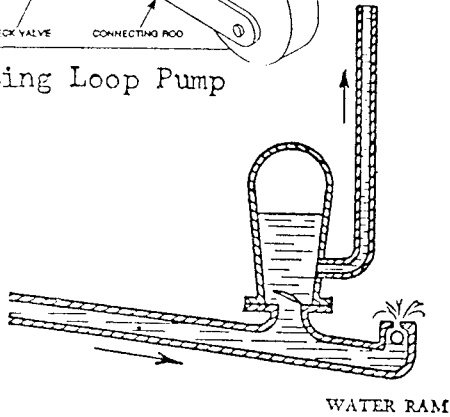

WATER RAM

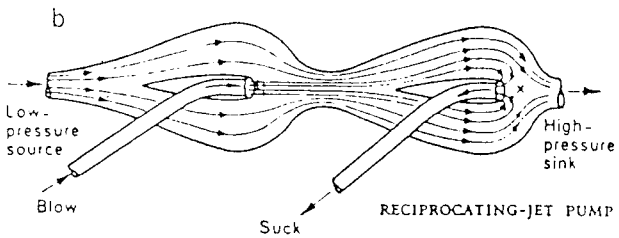
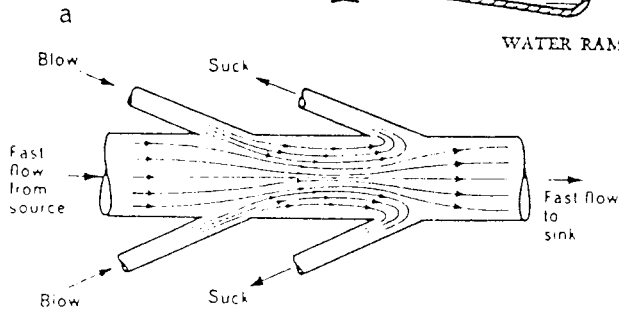

RECIPROCATING-JET PUMP

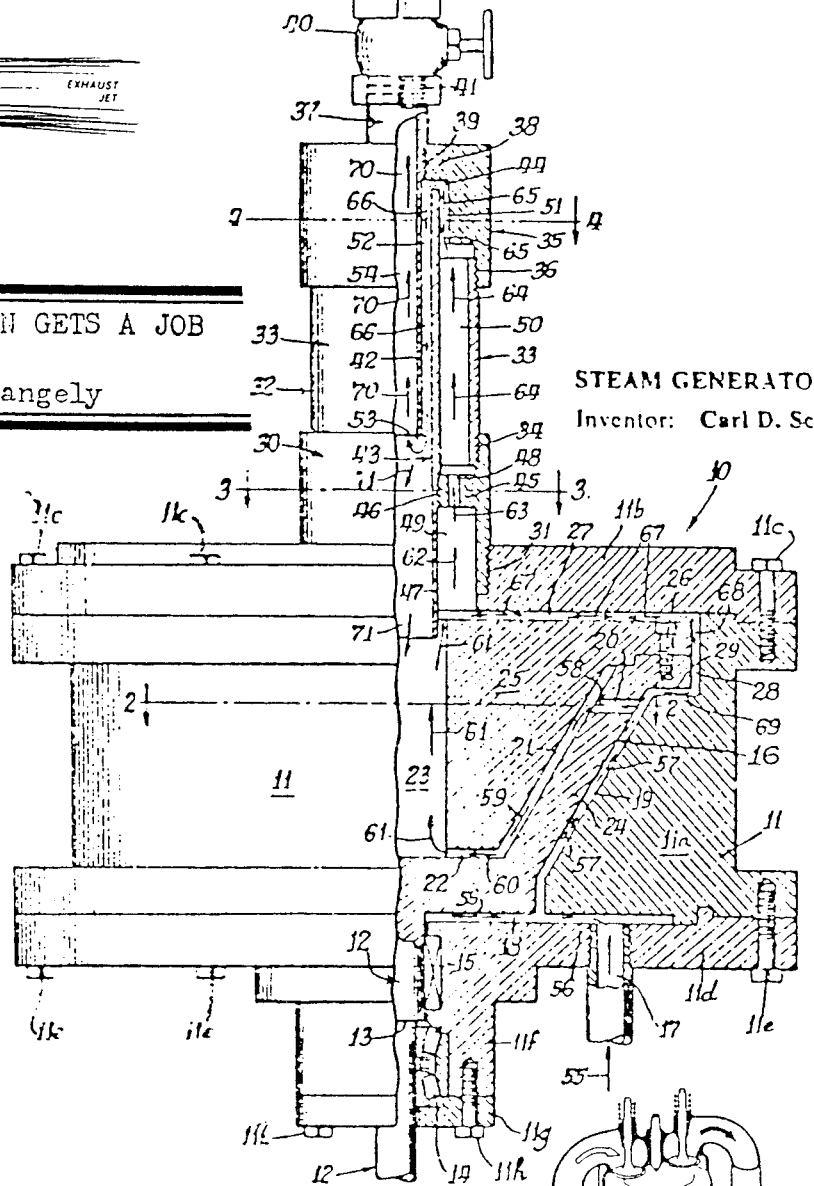

STEAM GENERATOR

Inventor: Carl D. Schaefer

COMPREX pressure-wave machine, used for charging diesel engines

- a = Engine
- b = Cell-wheel
- c = Bell drive
- d = High-pressure exhaust gas
- e = High-pressure air
- f = Low-pressure air intake
- g = Low-pressure gas outlet

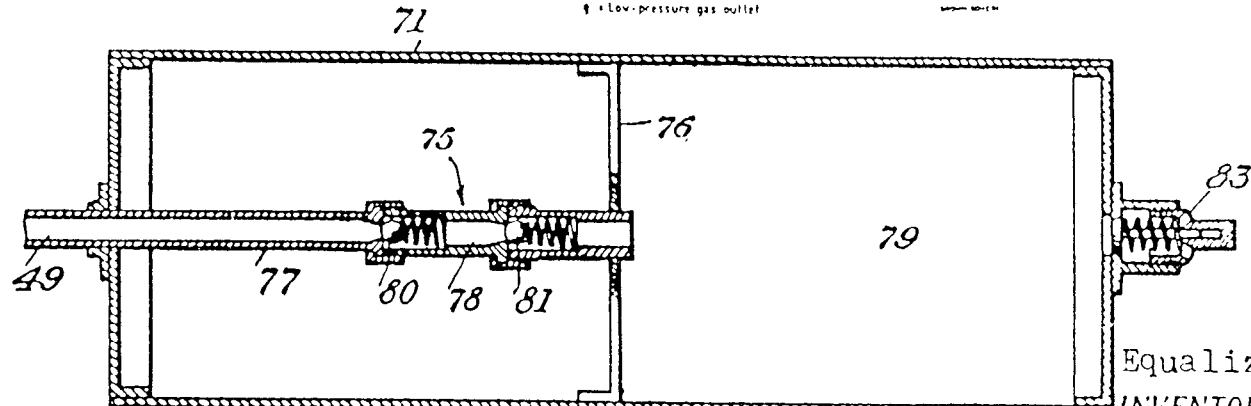
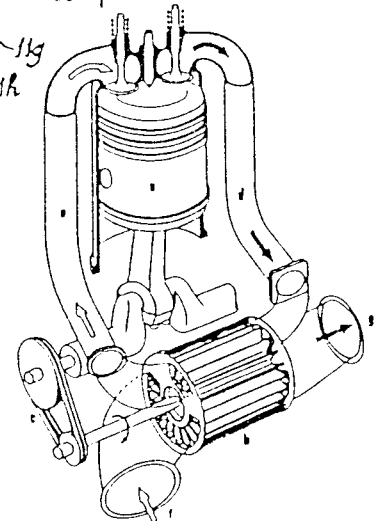

Equalizer INVENTOR.

Bob Neal

MAXWELL'S DEMON GETS A JOB
Secrets of the Self-fueling Air Car

by Scott Robertson

- Introduction: O.K., LET'S KEEP IT SIMPLE
- Chapter One: STALKING THE EQUALIZER.....1-12
How I ignored what I already knew long enough
to figure it out for myself.
- Chapter Two: JARGON-INVOTING FAILS TO LIMIT PNEUMATIC OPTIONS ...
How can you say what you mean when the terms ...13-26
that the scientific establishment has provided
for describing compressed air with are
already saying it all wrong, and that's the
only reason you had anything to say to begin
with?
- Chapter Three: STATE-OF-THE-ART PEACE SINES27-34
You wouldn't have believed it if they'd told
you in school, so they didn't tell you. Evi-
dence from scientific literature points out
that we can achieve the impossible by making
waves in the right place at the right time.
- Chapter Four: "THE REST IS TOP SECRET".....35-42
The U.S. Patent Office doesn't grant patents
for perpetual motion machines, but it does
grant patents for self-fueling air cars. Ex-
cerpts from patent papers, and the author's
comments, on some of the compressed air power
plants that seem to invoke Maxwell's Demon.
- Chapter Five: PARAPHRASES OF IMP-POSSIBILITIES43-147
Establishment science get out of the way!
Someone 'round here is fixin' to change the
static potential. Dolphin-powered air recyc-
ling machines, an exclusive interview by the
author, excerpts from books, magazines and
newspapers.
- Chapter Six: PATENT PAPERS AND OTHER GOOD LUCK CHARMS ..148-196
Good luck profiting from a pioneering energy
invention, with the good old patent office
standing in your way protecting you. Several
complete patent papers.
- Bibliography: WHAT I HAD TO READ SO YOU WOULDN'T HAVE TO ..197-205

AIR-POWER MOTORS AND APPLIANCES.

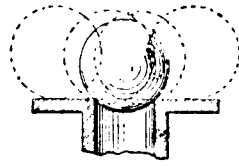

333. PNEUMATIC BALL PUZZLE. A ball laid on the mouth of a flanged tube, as in the cut, can not be blown off by an air jet, but will continue to roll around on the flange, as shown by the dotted lines.

334. PNEUMATIC DISK PUZZLE. A light circular plate with pin guides can only be lifted a small distance by an air jet from the flanged tube. The theory is that the momentum of the air as it suddenly spreads to a larger circumference causes a partial vacuum near the outer edge, thus holding the plates so near together that their circumferential area corresponds with the area of the central jet.

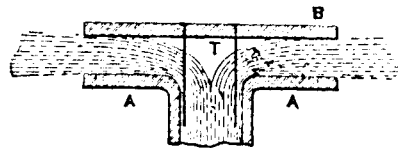

335. PNEUMATIC BALL PUZZLE. A light ball is held in a jet of air from a vertical to an angle of about 30° and revolves with considerable velocity.

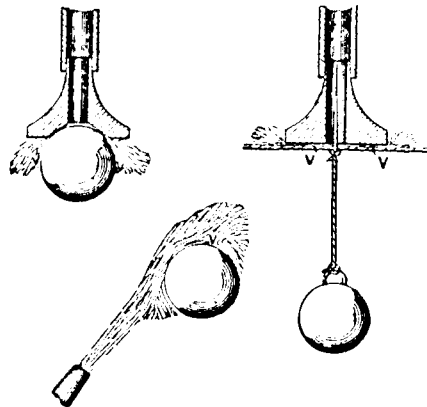

A light ball placed in a conical cup over a jet of air will be held there and not driven off when the cup and jet are reversed.

A card placed on an inverted flanged jet of air, as at V, V, will not drop, even with a considerable weight hanging to it.

336. Inverted nozzle and ball.

337. Inverted nozzle with ball attached to plate.

Compression Wave Pump

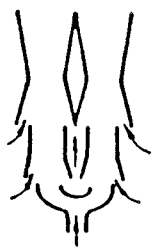
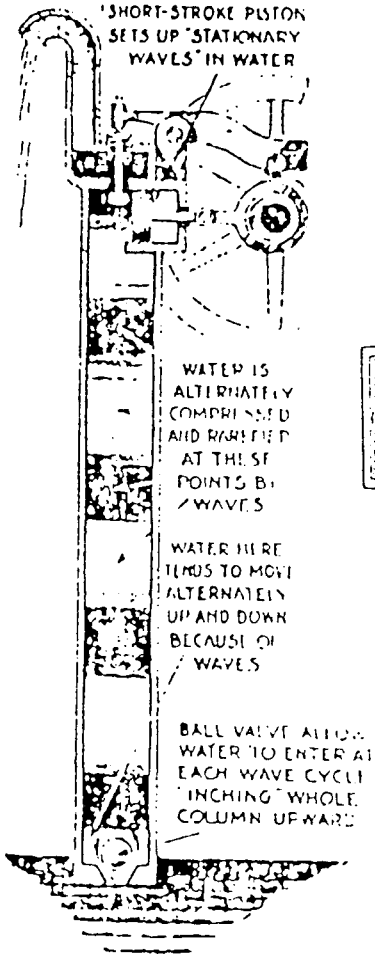

Pulse-jet aspirator
"Kylchap"

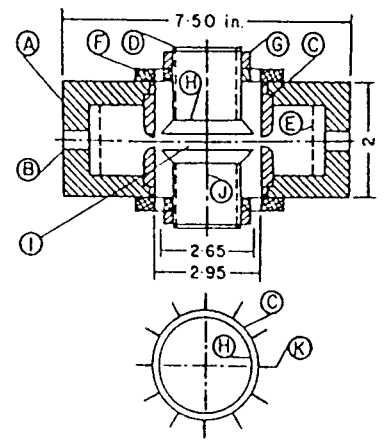

- A PLENUM CHAMBER
- B AIR INLET
- C NOZZLE RING
- D THREADED ROD
- E WIND SCREEN
- F SLOTTED PLATE
- G LOCKING RING
- H RESONATOR DISC
- I RESONATOR CAVITY
- J OPTICAL PATH
- K CIRCULAR JET

cylindrical resonator

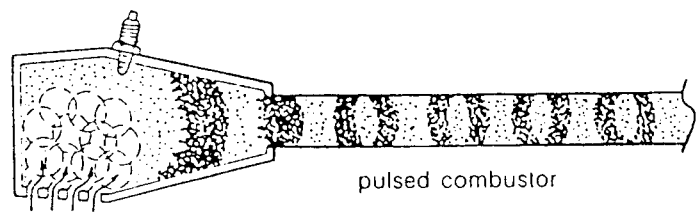

pulsed combustor

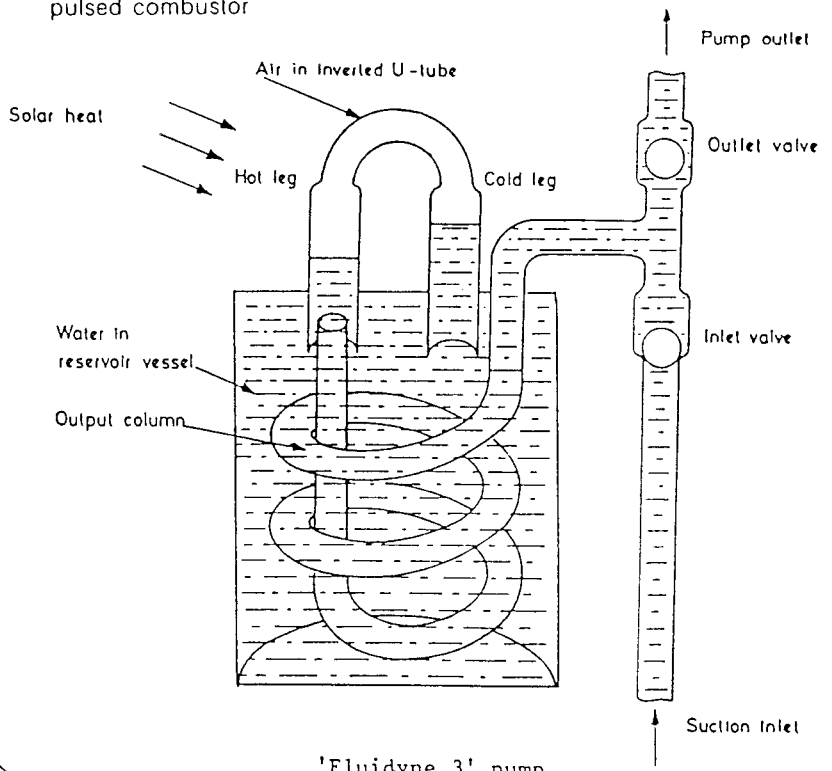

'Fluidyne 3' pump

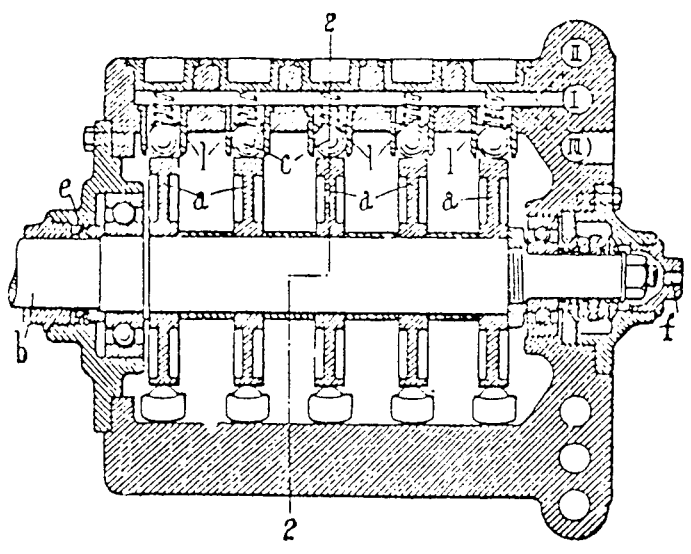

G. CONSTANTINESCO.
SYNCHRONOUS ALTERNATING LIQUID CURRENT MOTOR.

**MAXWELL'S DEMON;
THE LITTLE SHOCK
WAVE THAT COULD!**

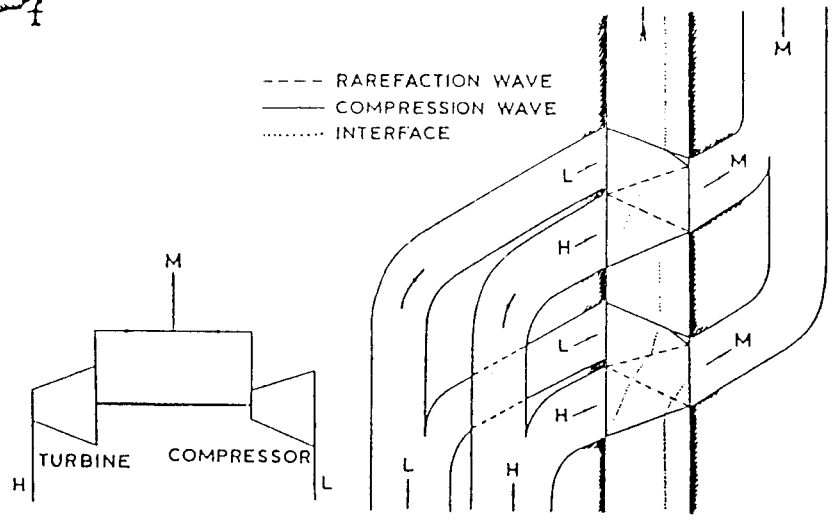

a equalizer, utilizing compressor-turbine set.

b equalizer, utilizing a two cycle DPE.

Equalizer